

KSE 1551 i

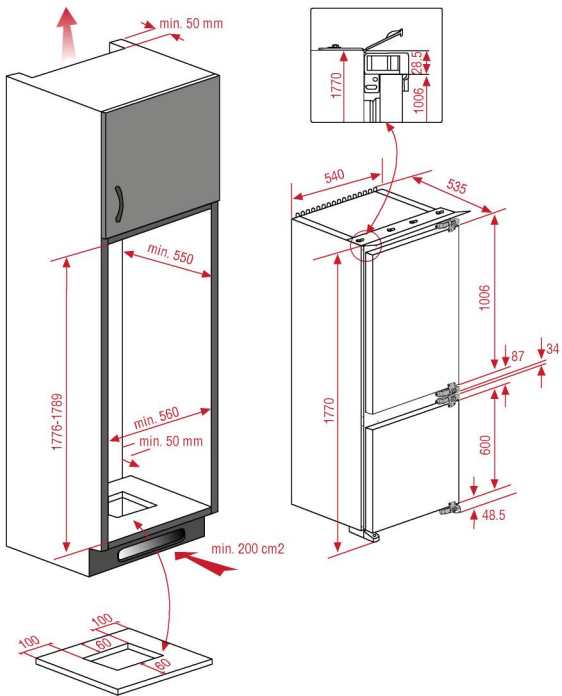

DSM 1510 i

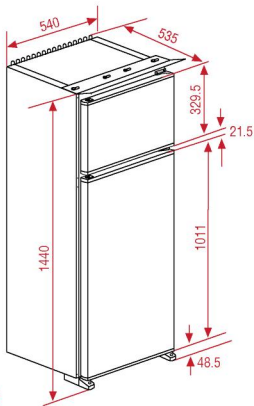

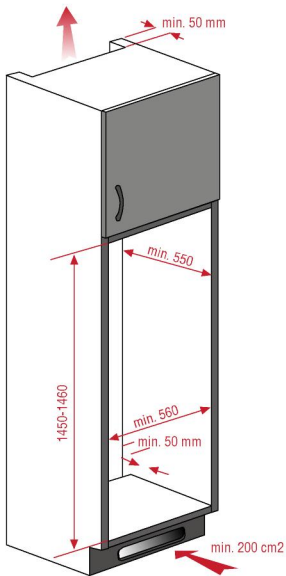
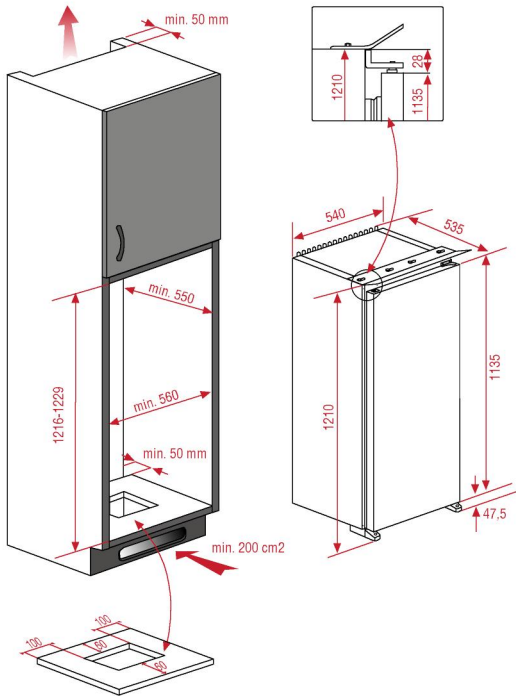

TSM 1550 i

TSM 1540 i

FTM 1530 i

